

auto electrical parts

Technical Information Sheet

Part No. 0-085-50

Commercial rear lamp, universal. 24 volt LED stop/tail/fog/direction indicator/reflex reflector/reverse, pre-wired. I 341 x w 61 x h 132mm. ECE approved.

Additional information

1m flying lead, cable outlet at rear.

Wiring:

White: -ve	Red: Stop
Yellow: Indicator	Green: Fog
Black: Reverse	Brown: Tail/No Plate

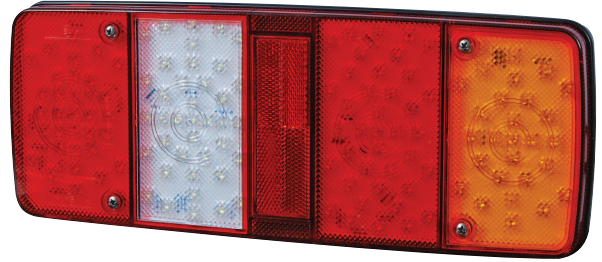

Technical Drawing (not to scale)

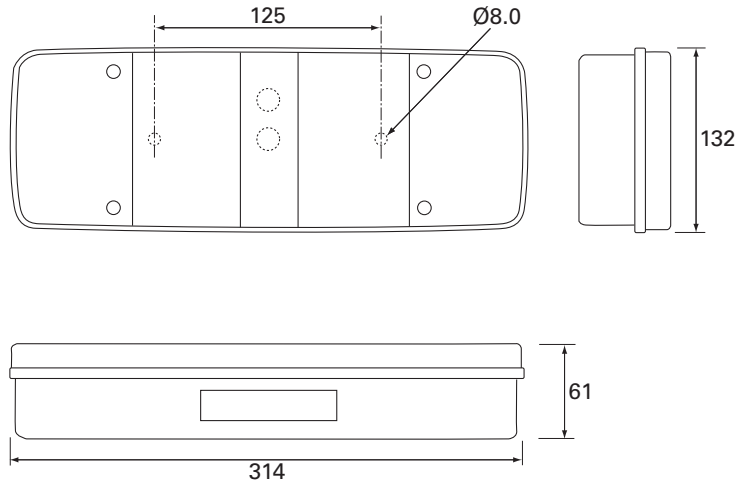

Specification

Type	LED commercial rear lamp stop/tail/ fog/direction indicator/reflex reflector/reverse.
Voltage	24 volt dc
LED	Stop/Tail 27 red, fog 33 red, indicator 27 amber, reverse 39 white, No plate 12 white
Lens	Acrylic
Housing	ABS
Fixing	2 x M8 x 35mm bolts (supplied)
Weight	1.10kg
Dimensions	see diagram
Certification	ECE

The information contained in this document is correct to the best of our knowledge at the time of printing. However, specifications may change at any time without notice.